

EMH-series

EMH-120, EMH-250U

FEATURES



All Stainless steel made, Polished Housing.
Intended for **heavy duty work** in commercial food processing applications.
Compact designs make the grinder ideal for open kitchens application or front end meat operations.
Energy efficient motor with cooling fan and **precision gear drive**.
Complete with **forward-reverse switch** and **reset button**.
Strict complies with **hygiene standards**.
Equipped with an **electromotor overload protection device**.
Compact size with no sharp corners or seams.

SPECIFICATIONS

Model	Capacity	Basic Electrical	Current input nominal	Power input	Circuit Breaker	Fequency rotation of blade	Nominal torque shaft	Lenght of power cord
	Kg/h							
EMH-120	120	220 - 240/50/1	3,5	750	16	170	3,71	1,8
EMH-250U	250	380/50/3	2,9	1100	16	170	6,0	1,8

FEATURES

The **Unger system** garantees effective processing harder meat pieces.



WARRANTY

All parts coverage for one year.

PACKING&SHIPPING

Model	Unit dimensions	Unit Weight	Packing dimensions	PackingWeight	Loading quantity	
	(W x D x H), mm		(W x D x H), mm		pcs/20'	pcs/40'
EMH-120	235x425x420	20	310x450x480	23	420	840
EMH-250U	245x465x530	37	585x465x455	40	215	430

OPERATING REQUIREMENTS

	Minimum	Maximum
Air Temperatures	10°C	35°C
Electrical Voltage	-5%	+10%
Rated capacity of wire	10 A	16 A
Section area of wire	0,75 mm ²	1,0 mm ²

INSTALLATION

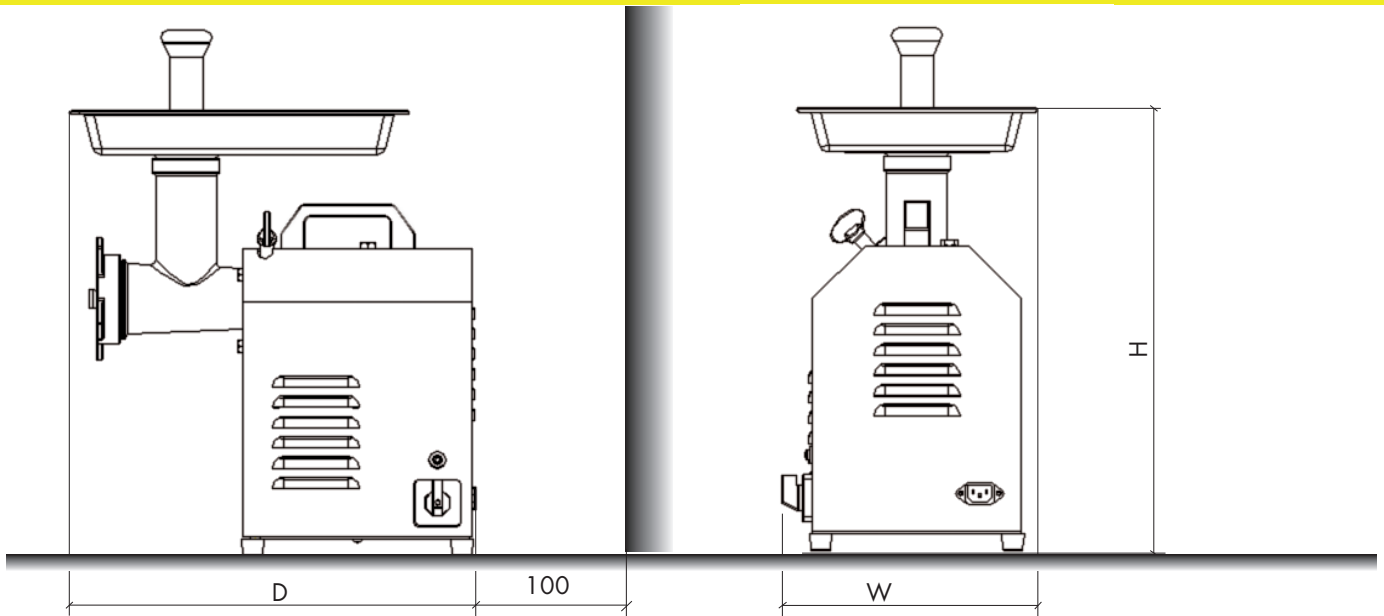

ACCESSORIES

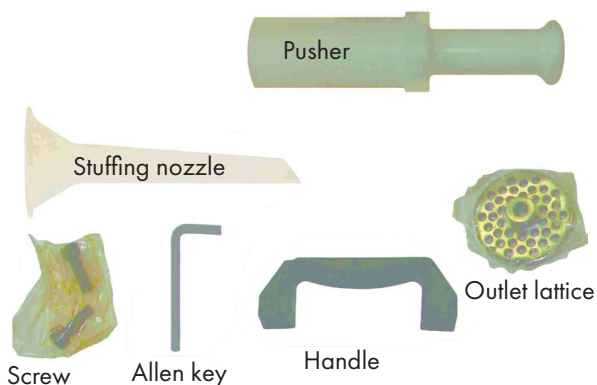

CERTIFICATION



Meat Grinder EMH-series have been tested for compliance with Directives 89/336/EEC and 72/23/EEC, as evidenced by certificates of CE, given by the company "TUV SUD Product Service GmbH".