

## ELH-series

## ELH-220S, ELH-250S, ELH-300S

### FEATURES



Slicers ELH-series are made a **strictly set thickness**.

Slicers adjustment knob has an easily **readable scale**.

**Angled body and transparent shatterproof plastic protection screen** guarantee comfort and high productivity.

**Built-in** sharpening device. The blade can be instantly **straightened and sharpened**.

Safety is the highest priority. The blade is **hidden behind a protection case** and is open only in the cutting zone.

**Dirt-protected button** with backlight and firm rubber feet.

100% hygienic. Easily cleaned **aluminium alloy body** is covered by transparent enamel.

Knife sharpening **auto power off** device. When knife sharpening move out from running machine, power off device.

**Poly V-Belt** drive system provides a quiet operating slicer.

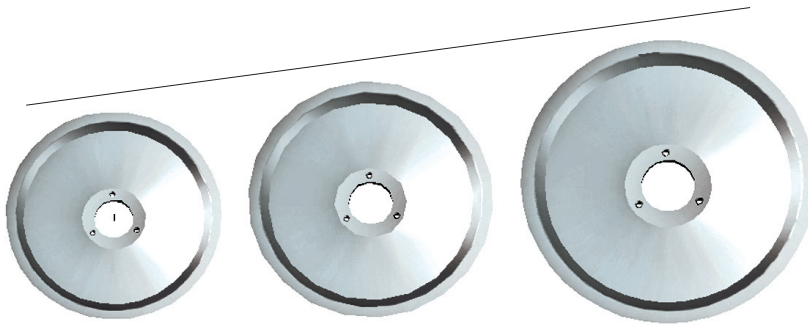

Precision crafted knife are made of quality material

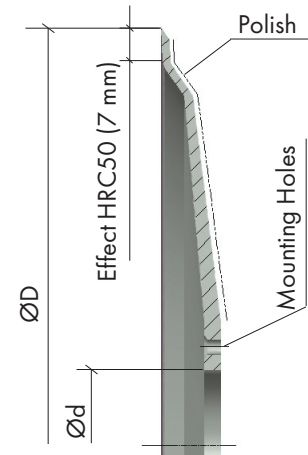

Model	Material	D, mm	Mounting holes	d, mm
EKH-220C	Carbon Steel with Hard Chrome Finish 4Cr13	Ø 220	3x6,0 mm	Ø 40
EKH-250C	Carbon Steel with Hard Chrome Finish 4Cr13	Ø 250	3x6,8 mm	Ø 40
EKH-300C	Carbon Steel with Hard Chrome Finish 4Cr13	Ø 300	3x6,9 mm	Ø 40

### SPECIFICATIONS

Model number	Knife Diameter	Basic Electrical	Current input maximum	Power input	Circuit Breaker	Maximum load	Frequency rotation of motor	Thickness of slice
	mm	V/Hz/Phase	A	W	A	W	RPM	mm
<b>ELH-220S</b>	Ø 220	220 - 240/50/1	1,1	130	6	520	1400	0 - 13
<b>ELH-250S</b>	Ø 250	220 - 240/50/1	1,3	180	6	600	1400	0 - 15
<b>ELH-300S</b>	Ø 300	220 - 240/50/1	1,4	210	6	650	1400	0 - 17

### WARRANTY

All parts coverage for one year including knife.

## PACKING&SHIPPING

Model	Unit dimensions	Unit Weight	Packing dimensions	PackingWeight	Loading quantity	
	(W x D x H), mm	Kg	(W x D x H), mm	Kg	pcs/20'	pcs/40'
<b>ELH-220S</b>	410x355x350	15	465x400x430	17,5	420	840
<b>ELH-250S</b>	535x475x490	23	585x465x455	25,5	230	460
<b>ELH-300S</b>	570x412x460	40,5	635x535x525	55,5	160	320

## OPERATING REQUIREMENTS

	Minimum	Maximum
Air Temperatures	10°C	35°C
Electrical Voltage	-5%	+10%
Rated capacity of wire	6 A	10 A
Section area of wire	0,75 mm <sup>2</sup>	1,0 mm <sup>2</sup>

## INSTALLATION

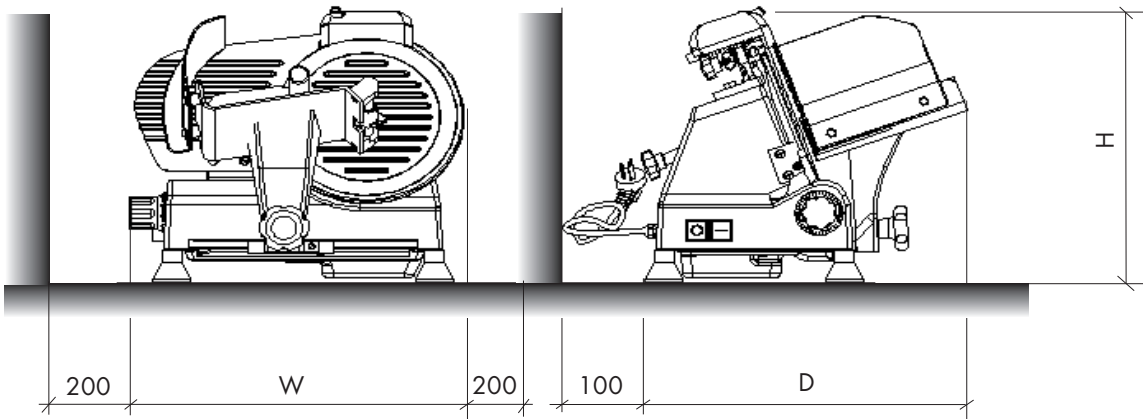

## ACCESSORIES



Grindstone



Belt



Protective screen

## CERTIFICATION



Slicers ELH-series have been tested for compliance with Directives 89/336/EEC and 72/23/EEC, as evidenced by certificates of CE, given by the company "TUV SUD Product Service GmbH".